



UNIVERSITY OF CAMBRIDGE INTERNATIONAL EXAMINATIONS
General Certificate of Education
Advanced Subsidiary Level and Advanced Level

PHYSICS

9702/34

Paper 32 Advanced Practical Skills 2

May/June 2010

CONFIDENTIAL INSTRUCTIONS

Great care should be taken to ensure that any confidential information given does not reach the candidates either directly or indirectly.

No access to the Question Paper is permitted in advance of the examination.



If you have any problems or queries regarding these Instructions, please contact CIE
by e-mail: international@cie.org.uk,
by phone: +44 1223 553554,
by fax: +44 1223 553558,
stating the Centre number, the nature of the query and the syllabus number quoted above.

This document consists of **8** printed pages.



Preparing apparatus

These instructions detail the apparatus required for the experiments in the Question Paper. It is essential that absolute confidentiality is maintained in advance of the examination: the contents of these instructions must not be revealed either directly or indirectly to candidates.

No access is permitted to the Question Paper in advance of the examination.

If you have problems or queries regarding these instructions, please contact CIE:

by e-mail: international@cie.org.uk,
or by telephone: +44 1223 553554,
or by fax: +44 1223 553558,

stating the nature of the query and quoting the syllabus and paper numbers (9702/34).

It is assumed that the ordinary apparatus of a Physics laboratory will be available.

Number of sets of apparatus

The number of sets of apparatus provided for each experiment should be $\frac{1}{2}N$, where N is the number of candidates taking the examination. There should, in addition, be a few spare sets of apparatus available in case problems arise during the examination.

Organisation of the examination

Candidates should be allowed access to the apparatus for each experiment for one hour only. After spending one hour on one experiment, candidates should change over to the other experiment. The order in which a candidate attempts the two experiments is immaterial.

Assistance to Candidates

Candidates should be informed that, if they find themselves in real difficulty, they may ask the Supervisor for practical assistance, but that the extent of this assistance will be reported to the Examiner, who may make a deduction of marks.

Assistance should only be given:

when it is asked for by a candidate,
or as directed in the Notes sections of these instructions,
or where apparatus is seen to have developed a fault.

Assistance should be restricted to enabling candidates to make observations and measurements. Observations and measurements must not be made for candidates, and no help should be given with data analysis or evaluation.

All assistance given to candidates must be reported on the Supervisor's Report Form.

Faulty apparatus

In cases of faulty apparatus (not arising from a candidate's mishandling) that prevent the required measurements being taken, the Supervisor may allow extra time to give the candidate a fair opportunity to perform the experiment as if the fault had not been present. The candidate should use a spare copy of the Question Paper when the fault has been rectified or when working with a second set of apparatus.

Supervisor's Report

The Supervisor should complete the Supervisor's Report Form on pages 7 and 8 and enclose it in the envelope containing the answers of the candidates. If more than one envelope is used, a copy of the report must be enclosed in each envelope.

Question 1**Apparatus requirements (per set of apparatus, unless otherwise stated)**

Expendable spring with an outside diameter about 15 mm, coiled length about 20 mm and spring constant about 25 Nm^{-1} (e.g. Philip Harris product code 1397).

Cylindrical metal rod of length between 60 cm and 100 cm and diameter approximately 15 mm (e.g. the rod from a retort stand). See Note 1.

30 cm ruler with a millimetre scale.

Metre rule with a millimetre scale.

Stopwatch reading to 0.1 s or better.

Retort stand with a boss and clamp.

Triangular glass or wooden prism to act as a pivot.

Card on which is written the weight of the rod in N and the spring constant of the spring in Nm^{-1} , both given to 3 significant figures. This should be written as below.

$W = \dots\dots\dots \text{ N}$
$k = \dots\dots\dots \text{ N m}^{-1}$

Notes

- 1 One end of the spring should be secured to one end of the rod, so that it does not slip, for example as shown in Fig. 1.1.

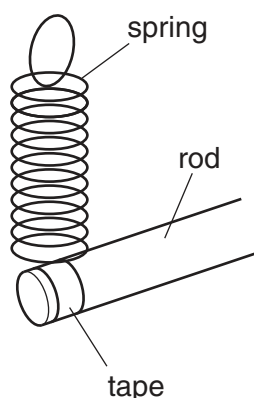
**Fig. 1.1**

- 2 If the apparatus is to be used by a second candidate, then it should be restored to its original state.

Information required by Examiners

Sample set of results, clearly labelled “Supervisor’s Results” and obtained out of sight of the candidates.

Question 2**Apparatus requirements (per set of apparatus, unless otherwise stated)**

Low-voltage d.c power supply, capable of supplying at least 4 A. See Note 4.

Rheostat capable of carrying at least 4 A. See Note 4.

Ammeter (preferably digital) with a range of at least 0–5 A to read at least to the nearest 0.1 A.

35 cm length of bare straight copper wire (16 swg or diameter 1.6 mm). See Note 1.

Two insulators e.g. corks or rubber bungs (see Fig. 2.1).

Four connecting leads.

Two crocodile clips.

Two retort stands, bosses and clamps.

Magnadur magnet with its poles on the faces of the magnet (e.g. Philip Harris product code 47156).

Stirrup to support the magnet (e.g. adhesive label). See Note 2.

Thin wooden stick of length 10 cm (e.g. a cocktail stick).

50 cm of monofilament nylon thread (e.g. fishing line). See Note 2.

Stopwatch reading to 0.1 s or better.

180° protractor.

30 cm ruler with a millimetre scale.

Notes

- 1 The copper wire must be bent into the shape shown in Fig. 2.1.

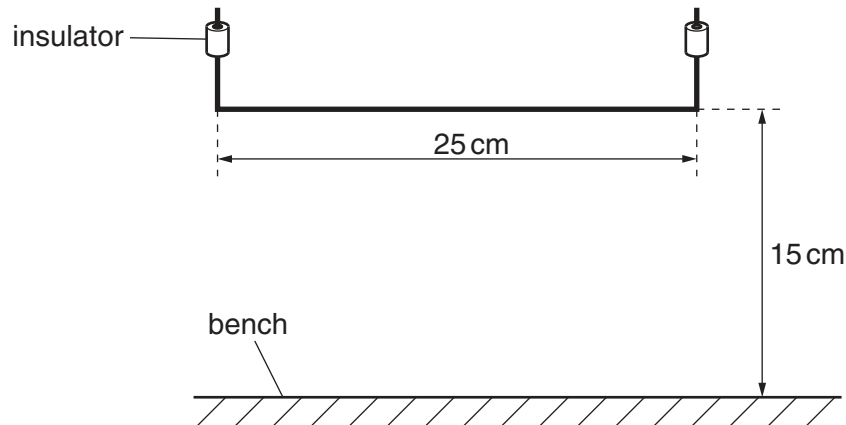

Fig. 2.1

The horizontal portion of the copper wire should be about 25 cm long. The vertical sections should each pass tightly through an insulator (e.g. a cork or rubber bung), which may then be clamped firmly.

Make electrical connections to the ends of the wires with crocodile clips.

The horizontal section of the copper wire should be about 15 cm above the bench.

- 2 The magnet should be firmly mounted in a paper stirrup attached to the nylon thread with its largest faces vertical.

The stirrup should extend no more than 1 cm above the top of the magnet.

The thin wooden stick should be attached along the centre of the bottom edge of the magnet.

A dotted line should be drawn on the stirrup parallel to and halfway between the edges of the magnet, as shown in Fig. 2.2.

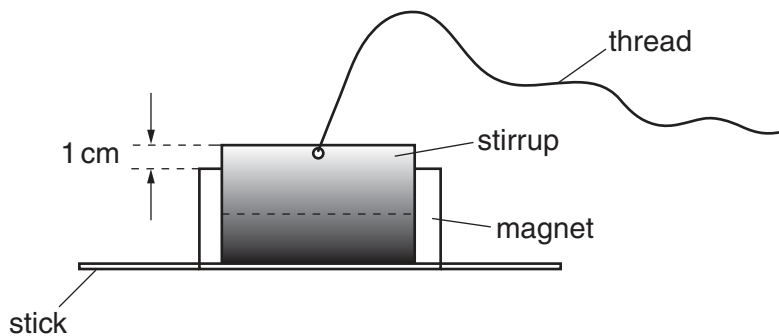

Fig. 2.2

- 3 The apparatus should be set up as shown in Fig. 2.3, with no current in the wire. The rheostat should be set to its **maximum** resistance position. The stands should be fixed (e.g. with adhesive tape) in a position such that the horizontal copper wire is approximately aligned in the north-south direction.

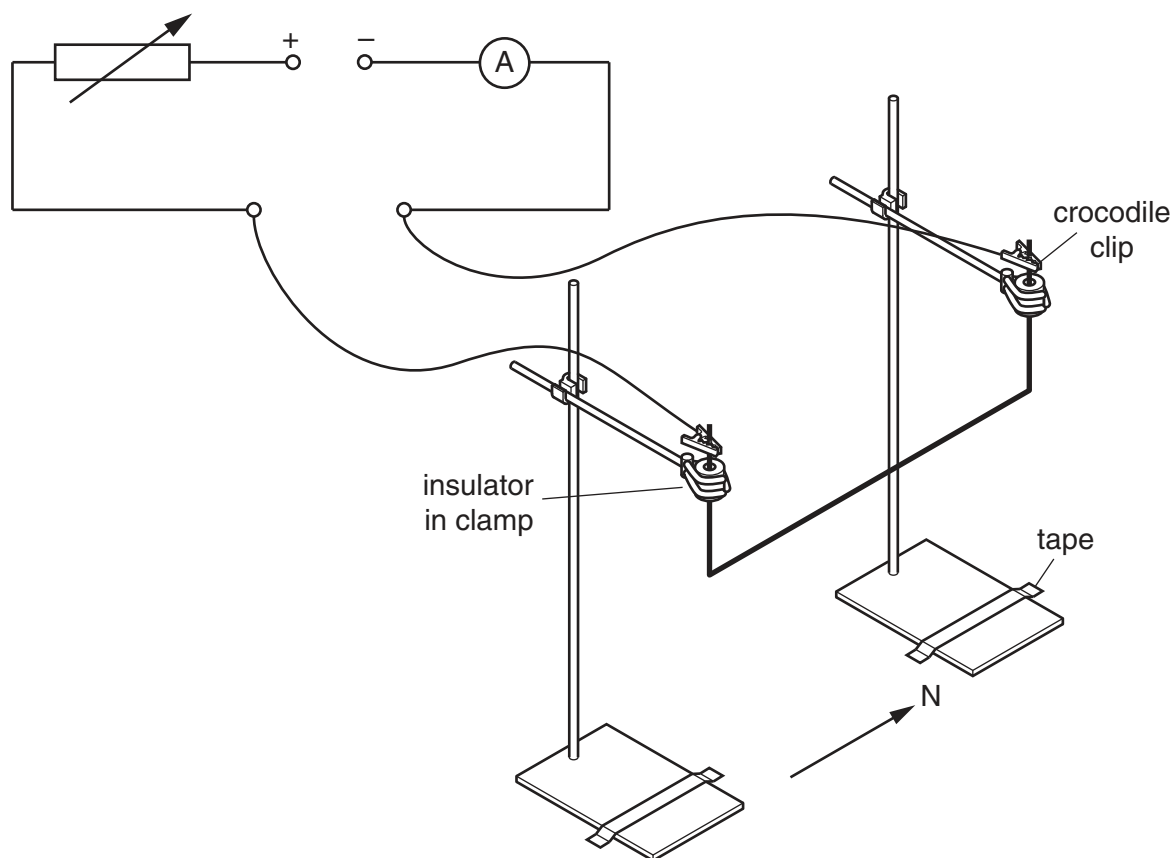

Fig. 2.3

- 4 The candidate will need to vary the current in the circuit in the range 0.3A to 3.0A. The Supervisor should accordingly use a power supply fixed to an appropriate e.m.f., and should choose a rheostat with sufficient maximum resistance. If necessary, a fixed resistor of an appropriate power rating may be included in the circuit.

Limit the movement of the rheostat so that the current in the circuit cannot exceed 4A (e.g. by wrapping tape around the slider rail). Then reset the rheostat to its maximum resistance position and switch off the current.

- 5 If the apparatus is to be used by a second candidate, then it should be restored to its original state.

Information required by Examiners

Sample set of results, clearly labelled “Supervisor’s Results” and obtained out of sight of the candidates.

Permission to reproduce items where third-party owned material protected by copyright is included has been sought and cleared where possible. Every reasonable effort has been made by the publisher (UCLES) to trace copyright holders, but if any items requiring clearance have unwittingly been included, the publisher will be pleased to make amends at the earliest possible opportunity.

University of Cambridge International Examinations is part of the Cambridge Assessment Group. Cambridge Assessment is the brand name of University of Cambridge Local Examinations Syndicate (UCLES), which is itself a department of the University of Cambridge.

This form should be completed and sent to the Examiner with the scripts.

SUPERVISOR'S REPORT FORM

General Certificate of Education Advanced Subsidiary Level and Advanced Level

May/June Session 2010

The Supervisor's Report should give full details of:

- (a) any help given to a candidate (including the nature of the help given and the name and candidate number of the candidate);
- (b) any cases of faulty apparatus (including the nature of the problem, the action taken to rectify it, any additional time allowed, and the name and candidate number of the candidate);
- (c) any accidents that occurred during the examination;
- (d) any other difficulties experienced by candidates, or any other information that is likely to assist the Examiner, especially if this information cannot be discovered in the scripts.

Cases of individual hardship, such as illness, bereavement or disability, should be reported direct to CIE on the normal Special Consideration form.

Information required by Examiners

For each question, please enclose a sample set of numerical results, obtained out of sight of the Candidates and clearly labelled "Supervisor's Results".

Supervisor's Report



Supervisor's Report (continued)

Declaration

(to be signed by the Supervisor)

The preparation of this practical examination has been carried out so as to maintain fully the security of the examination.

Signed

Name

Centre Number

Name of Centre

